

## *CS-652 Pneumatic Flat Press Machine*

### Operation Manual

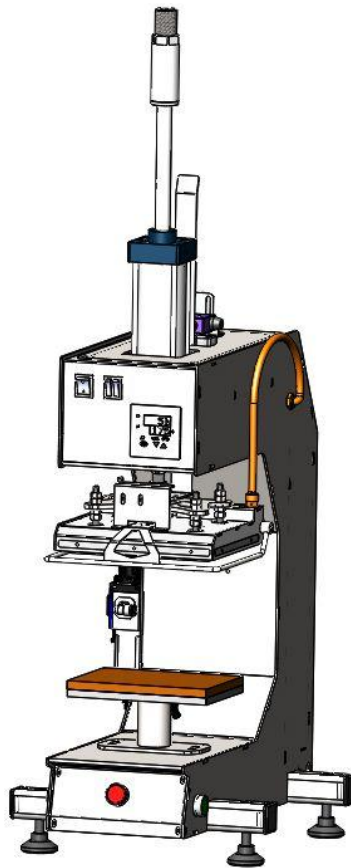

is powered by

**H&H Asia Group Limited**

e = [service@hh.com.hk](mailto:service@hh.com.hk)  
t = 852.24813068  
f = 852.24813727

Room 1117, 11/F, Asia Trade Centre, 79 Lei Muk Road, Kwai Chung, N.T., Hong Kong

## Table of Contents

**Precautions with regard to Safety**

**Name Plate**

**Introduction**

**Specifications**

**Machine Components**

**Control Console**

**Preparation Before Main Power Connected**

**Operation Mode Selection**

**Machine Operation**

**Machine Setting**

Control Panel

Control Panel General Display

Temperature Setting Adjustment

Press Timer Adjustment

Press Pressure Adjustment

**Trouble Shooting**

**Appendix A Control Circuit Schematic Diagram**

> Precautions with regard to Safety

Please observe these safety tips for safe, efficient, an injury-free operation of your equipment. By strictly following all instruction contained in this manual you will certainly obtain an excellent performance from the use of this equipment for years.

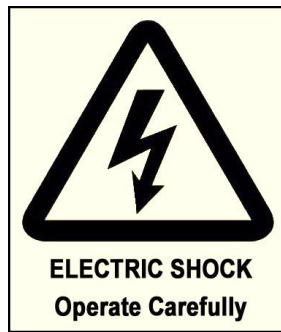

> Precautions with regard to Safety (cont.)

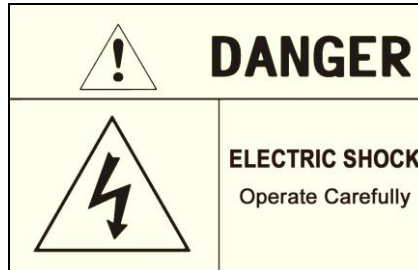

> Name Plate

<b>Model : CS-652</b>				
<b>Pneumatic Flat Press Machine</b>				
spec A-A1A1-020015				
<b>Voltage</b>	<b>Frequency</b>	<b>Power</b>	<b>Compressed Air</b>	<b>Weight</b>
220 V	50/60 Hz	1000 W	>0.4 Mpa	45 Kg
<b>Date :</b>			<b>S/N :</b>	

**H&H Asia Group Ltd.**  
Room 1117, 11/F, Asia Trade Centre, 79 Lei Muk Road, Kwai Chung, N.T., Hong Kong  
Tel : (852) 2481-3068 Fax : (852) 2481-3727  
[www.hh.com.hk](http://www.hh.com.hk)  
MADE IN CHINA



**> Introduction**

Thank you for your choosing of CS-652 which is manufactured by H&H.

The pneumatic flat press machine described in this manual is one of the sophisticated machines for processing the flat press products in the market today. Built on digital control platform and designed for the professional users. Operators are recommended to have basic knowledge and skill in heat press operation before using this machine.

This manual is aimed for the operators to understand the machine and avoid damage to the machine or personnel. Please read this manual carefully and keep it well for daily reference usage.

**> Specifications**

Model	:	CS-652
Voltage	:	220 V, single phase
Frequency	:	50/60 Hz
Power Consumption	:	1000 W
Compressed Air	:	>0.4 Mpa
Heat Temperature Range	:	Room Temperature~260°C
Press Duration	:	1-999 second, minute or hour
Heat Press Size	:	8" X 6"
Lower Platform Size	:	8" X 6"
Overall Dimensions	:	520mm (L) x 380mm (W) x 1050mm (H)
Overall Weight	:	45 kg

Note : due to continuous improvement, specifications are subjected to change without prior notification

> Machine Components

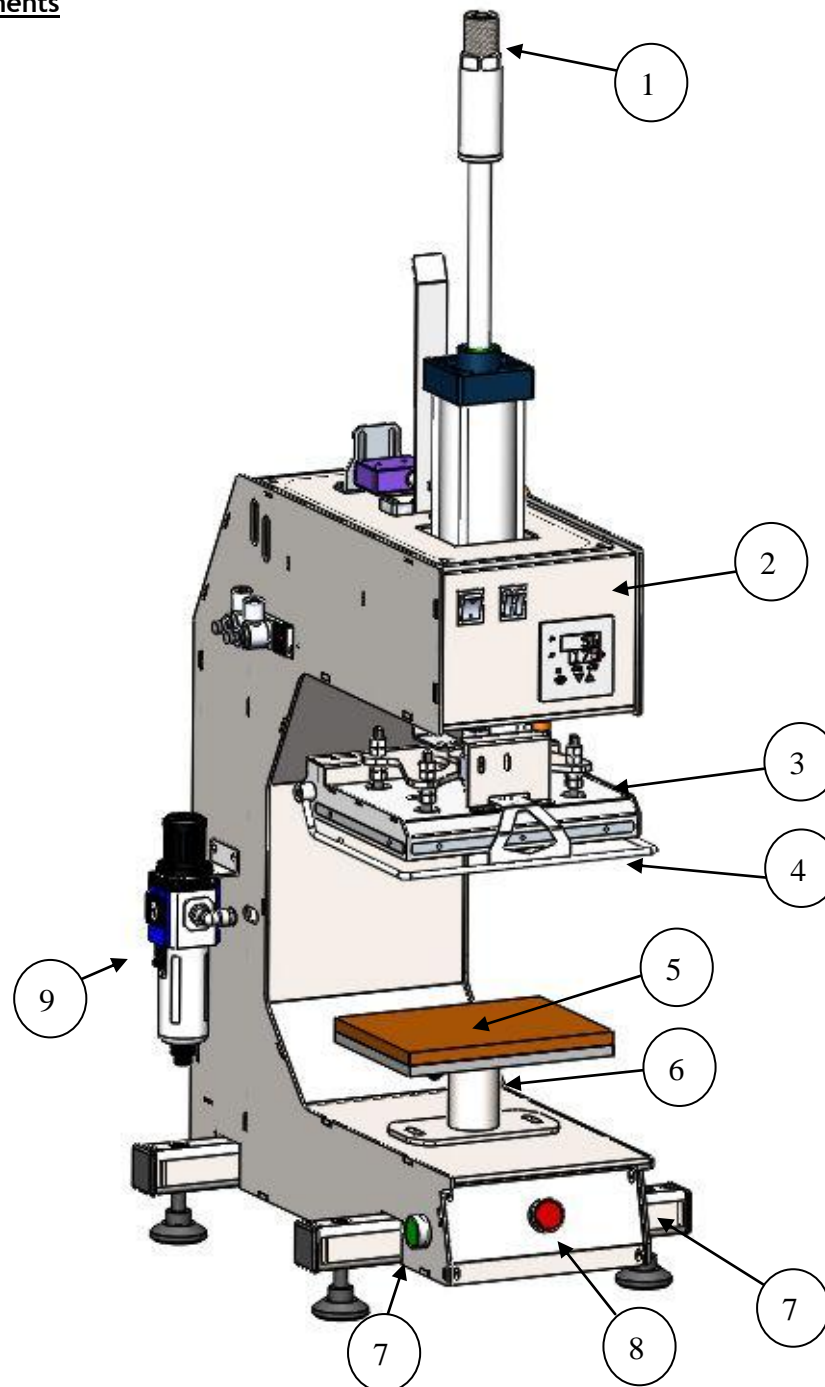

1. press pressure adjusting knot for the cylinder
2. control console
3. heating plate & pressing head
4. safety protective bar
5. lower platform
6. machine base
7. start buttons (must press both left & right buttons to activate)
8. cancel button
9. air filter and regulator



> Control Console

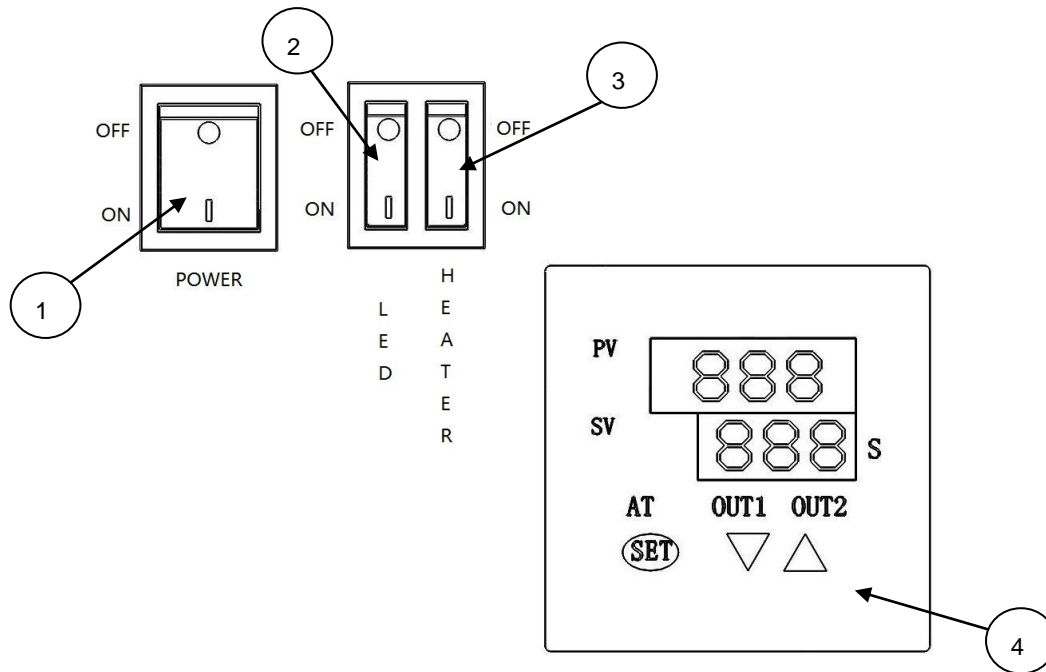

- |    |                   |   |   |
|----|-------------------|---|---|
| 1. | Main Power Switch | — | On / Off the Main Power                       |
| 2. | Led Light Switch  | — | On / Off the Led Light                        |
| 3. | Heater Switch     | — | On / Off the Heater                           |
| 4. | Control Panel     | — | Set the heat temperature setting & press time |

### > Preparation Before Main Power Connected

#### 1. Compress air connection

Since the heating plate will go up after compress air connected, the cable ties on the heating plate and the working table should be removed first.

#### 2. Main power connection

The main power cable with plug is located at the back of the machine, plug into the main power supply socket.

#### 3. Foot switch connection

The foot switch socket is located at the back of the machine, plug in the foot switch connector and tighten the screws.

### > Operation Mode Selection

The machine has two operation modes:

- A. Manual Push Button Mode - Press both the left & right start buttons at the front, the heating plate goes down, the timer starts to countdown. Once the timer is up or when you press the cancel button at the middle, the heating plate goes up.
- B. Pedal Control Mode - Step on the left foot switch, the heating plate goes down, after move away the foot, the timer starts to countdown. When the countdown is completed or you step into the right pedal, the heating plate goes up.

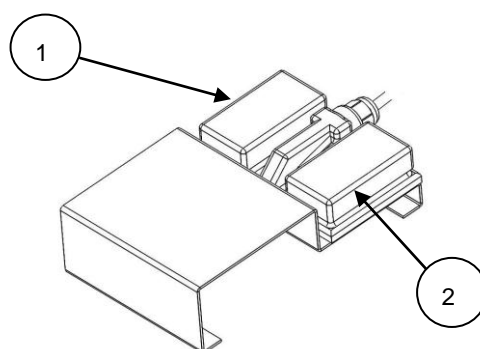

Pedal Switch

**> Machine Operation**

1. After connected the main power supply, adjust the heating temperature and time, press pressure, and planning the machine operation method (push buttons/pedal). Then turn on the heater power, the temperature of the heating plate will go up gradually.
2. Wait until the heating plate reaches the preset temperature. Place the cloth on the working table and step on the left foot switch once or press the start buttons at the front, the heating plate will go down. The timer will be triggered simultaneously. After the countdown finished, the heating plate will go up. The press cycle is completed.
3. If you step on the right foot switch once in the duration of countdown or press the cancel button at the front, the timer will stop immediately and the heating plate will go up, the press cycle will be terminated.
4. While the machine is working, the heating plate will go up automatically once the safety bar is triggered.
5. Switch off the main power after all the works are finished.

> **Machine Setting**

>> **Control Panel**

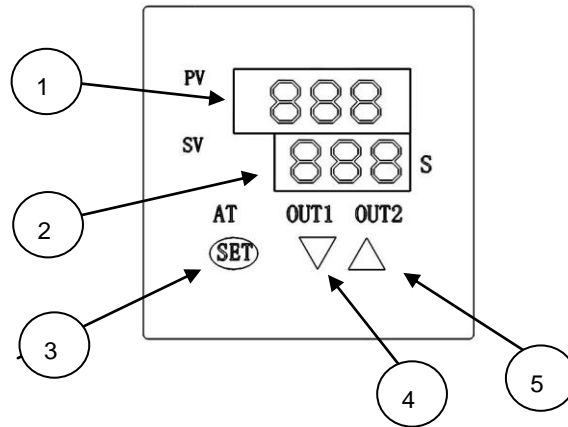

1. PV : Field processing temperature
2. SV : Set target temperature
3. SET : Select different settings
4. OUT1 : decrease the set point
5. OUT2 : increase the set point

>> **Control Panel General Display**

General appearance of the control panel is as the following diagram.

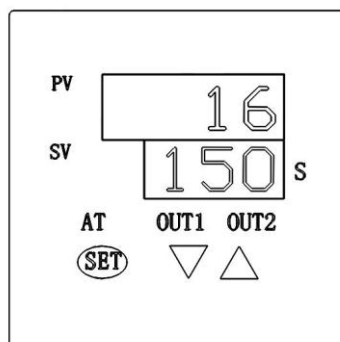

## > Machine Setting (Cont.)

### >> Temperature Setting Adjustment

Press the #3 (SET) once, the display will alike the below diagram. PV will show with “SH” and SV will show the preset temperature setting. You can press the OUT1 ”▽“ to decrease or OUT2 “△“ to increase the temperature setting. This machine is using degree C Celsius, the maximum setting is 400 C (we recommend the temperature setting below 260 C as a higher temperature will decrease the life span of the machine).

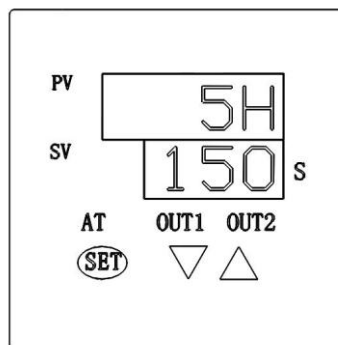

### >> Press Timer Adjustment

Press the #3 (SET) once again, the display will alike the below diagram. PV will show with “St” and SV will show the preset press time setting. You can press the OUT1 ”▽“ to decrease or OUT2 “△“ to increase the time setting. This machine is using second as the counting unit, the maximum setting is 999 seconds.

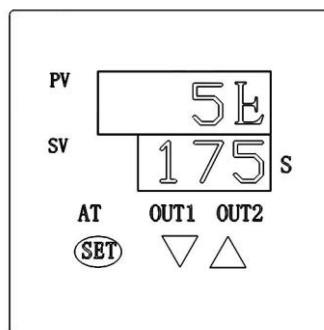

Press the #3 (SET) again, it will back to normal display mode.

### >> Press Pressure Adjustment

- Turning the knob on the compress air filter regulator to adjust the press pressure.
- Turning the press pressure adjusting knot for the cylinder to adjust the press pressure.
- By adjusting the four adjustment screws below the working table, the pressure of the press can also be changed, even under the same air pressure setting.

> **Trouble Shooting**

Problem	Cause	solution
No power to individual parts	Fault with power cord or plug	Check the power connection
	Circuit breaker tripped	Reset the breaker and investigate the system
	Main power supply not switch on	Switch on the main power supply
	Bad contact	Check the circuit if there is any loosen part
	Transformer fault	Check the voltage of power supply
Temperature monitor unsteady	Thermocouple fault	Replace the temperature sensor
	Thermocouple connection is loosen	Check and tighten the connection
	Temperature controller malfunction	Replace the circuit board in the control box
	Thermocouple extension cable short circuit	Check the break point and repair
	Thermocouple installed in wrong position	Check the end point of the sensor and relocate the position of it
Temperature monitor showing the ambient temperature	Heater not started up	Press the heat button
	Thermocouple fault	Replace the thermocouple
	Power supply voltage unsteady	Install voltage stabilizer
Heater temperature cannot raises up	Solid state relay (SSR) malfunction	Replace the SSR
	Compressed air pressure too low and interlocked	Increase the compressed air pressure

Appendix A . Control Circuit Schematic Diagram

