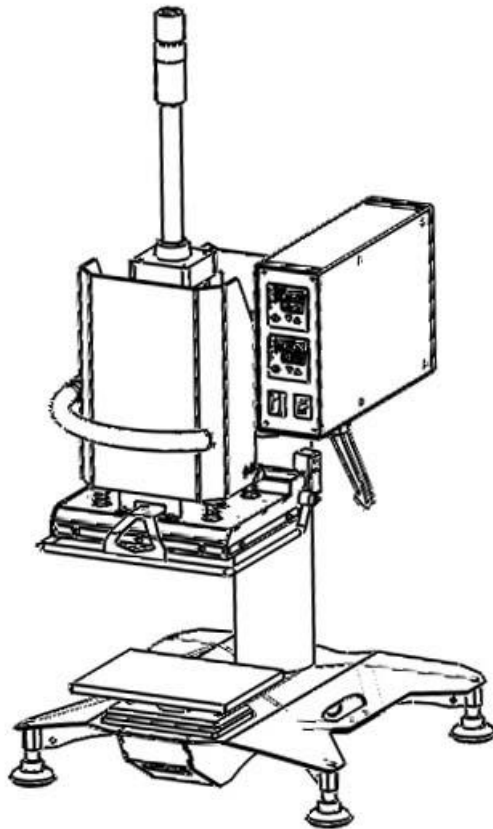

CS-330 Pneumatic Flat Press Machine**Operation Manual**

is powered by

H&H Asia Group Limited

e = service@hh.com.hk
t = 852.24813068
f = 852.24813727

Room 1117, 11/F, Asia Trade Centre, 79 Lei Muk Road, Kwai Chung, N.T., Hong Kong.

Table of Contents

Precautions with regard to Safety

Name Plate

Introduction

Specifications

Machine Components

Control Panel

Preparation Before Main Power Connected

Machine Operation

Machine Setting

 Temperature Controller Adjustment

 Press Timer Adjustment

 Press Pressure Adjustment

 Operation Mode Selection

Trouble Shooting

Appendix A Control Circuit Schematic Diagram

> Precautions with regard to Safety

Please observe these safety tips for safe, efficient, an injury-free operation of your equipment. By strictly following all instruction contained in this manual you will certainly obtain an excellent performance from the use of this equipment for years.

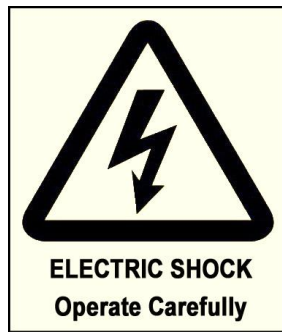

> Precautions with regard to Safety (cont.)

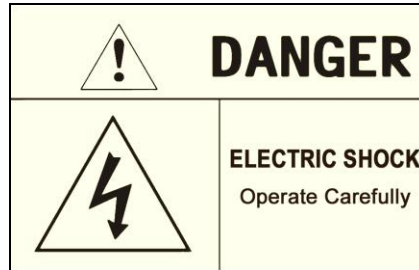

> Name Plate

Model : CS-330
Pneumatic Flat Press Machine

Voltage	Frequency	Power	Compressed Air	Weight
220 V	50/60 Hz	1000 W	>0.4 Mpa	54 Kg
Date :			S/N :	

H&H Asia Group Ltd.
Room 1117, 11/F, Asia Trade Centre, 79 Lei Muk Road, Kwai Chung, N.T., Hong Kong
Tel : (852) 2481-3068 Fax : (852) 2481-3727
www.hh.com.hk
MADE IN CHINA



> Introduction

Thank you for your choosing of CS-330 which is manufactured by H&H.

The pneumatic flat press machine described in this manual is one of the sophisticated machines for processing the flat press products in the market today. Built on pure digital control platform and designed for the professional users. Operators are recommended to have basic knowledge and skill in heat press operation before using this machine.

This manual is aimed for the operators to understand the machine and avoid damage to the machine or personnel. Please read this manual carefully and keep it well for daily reference usage.

> Specifications

Model	:	CS-330
Voltage	:	220 V, single phase
Frequency	:	50/60 Hz
Power Consumption	:	1000 W
Compressed Air	:	>0.4 Mpa
Heat Temperature Range	:	Room Temperature~300°C
Press Duration	:	1-999 second, minute or hour
Heat Press Size	:	8" X 6"
Lower Platform Size	:	8" X 6"
Overall Dimensions	:	600mm (L) x 500mm (W) x 1000mm (H)
Overall Weight	:	54 kg

Note : due to continuous improvement, specifications are subjected to change without prior notification

> Machine Components

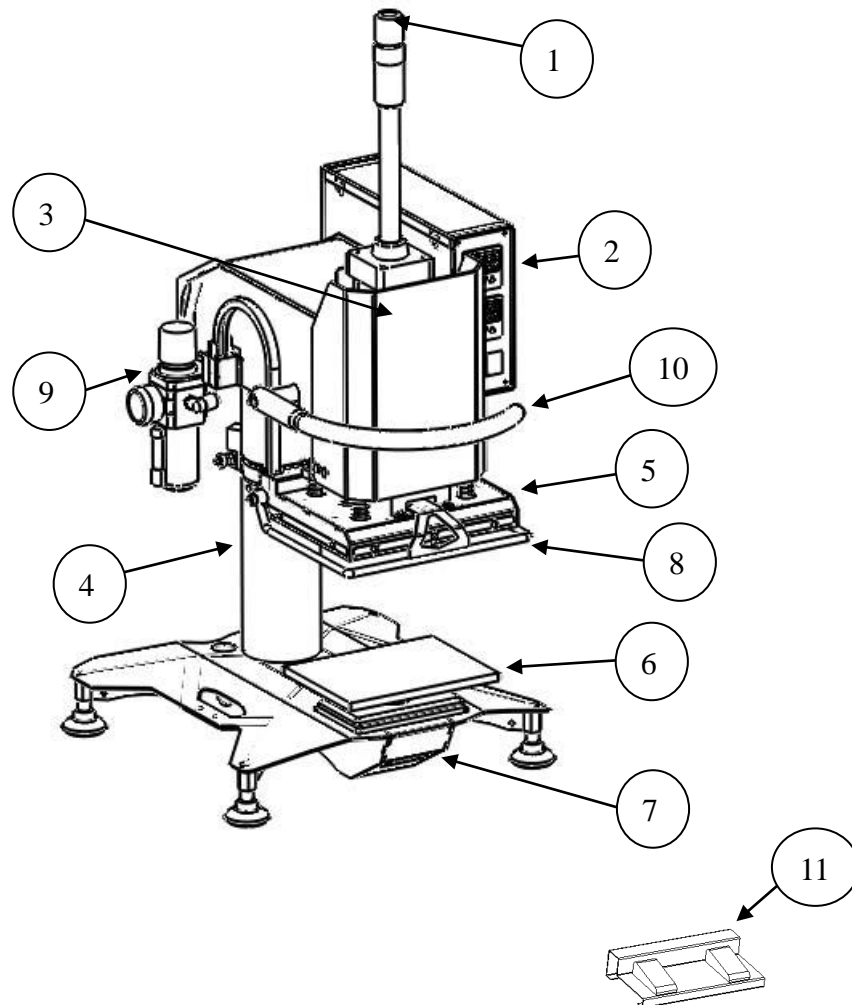

1. press pressure adjusting knot for the cylinder
2. control panel box
3. protecting cover
4. cylinder pole
5. heating plate & pressing head
6. lower platform
7. machine base
8. safety protective bar
9. air filter and regulator
10. manual control handle (control the heat press up/down)
11. foot pedal

> Control Panel

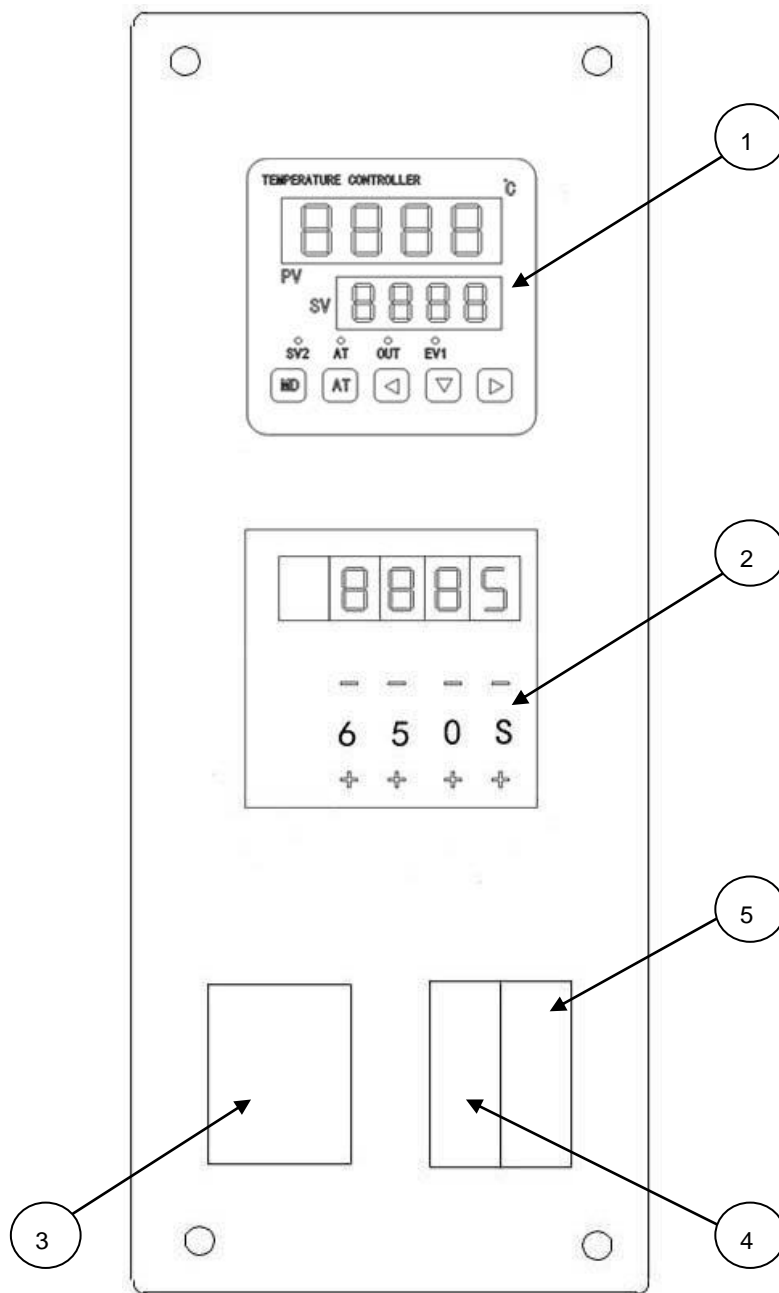

- | | | |
|---------------------------|---|---------------------------------|
| 1. Temperature Controller | — | Temperature Setting and Control |
| 2. Timer Controller | — | Display Press Time |
| 3. Main Power Switch | — | On / Off The Main Power |
| 4. Heater Switch | — | On / Off The Heater |
| 5. Manual / Auto | — | Select The Press Mode |

> Preparation Before Main Power Connected**1. Compress air connection**

Since the heating plate will go up after compress air connected, the cable ties on the heating plate and the working table should be removed first.

2. Main power connection

The 3-pin main power socket is located at the back of the machine, plug in the main power connector and tighten the screws

3. Foot switch connection

The 4-pin foot switch socket is located at the back of the machine, plug in the foot switch connect and tighten the screws.

> Machine Operation

1. After connected the main power supply, adjust the heating temperature and time, press pressure, and select the machine operation mode (manual/auto). Then turn on the heater power, the temperature of the heating plate will go up gradually.
2. Wait until the heating plate reaches the pre-set temperature. Place the cloth on the working table and step on the left foot switch once, then the heating plate will go down.
The timer will be triggered simultaneously. After the countdown finished, the heating plate will go up. The press cycle is completed.
3. If you step on the right foot switch once in the duration of countdown, the timer will be stop immediately and the heating plate will go up, the press cycle will be terminated.
4. While the machine is working, the heating plate will go up automatically once the safety bar is triggered.
5. Switch off the main power after the work is finished.

> Machine Setting

>> Temperature Controller Adjustment

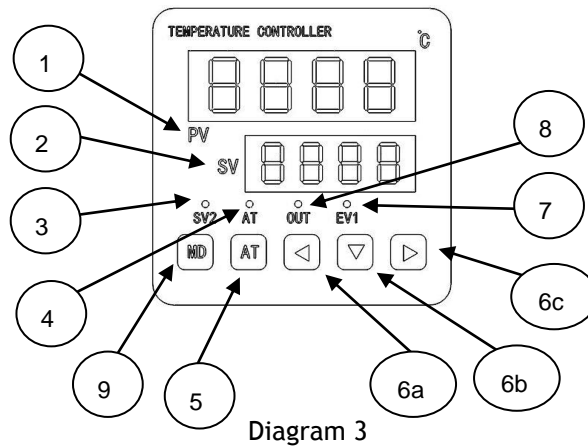

1. PV : Field processing temperature
2. SV : Set target temperature
3. SV2 : Action lamp
4. AT : Auto temp setting lamp
5. AT : Auto temp setting button
6. Position, increase/decrease buttons
7. EV1 output lamp
8. Output lamp
9. MD key : Mode select button

Press the “6a” button (See diagram 3) once or several times for selecting the value input position, press the up arrow “6b” button and down arrow “6c” button to change the temperature setting and press the MD key button to finish the temp preset. The preset target temperature will be stored automatically.

> Machine Setting (Cont.)

>> Press Timer Adjustment

The units, hour (H), minute (M) and second (S) can be selected in the timer. Normally, the unit-second (S) is mostly used. The value is set by using the “+” or “-”. For example, the press time 650 seconds, it can be set by using the “+” or “-” below the little squares (See diagram 4).

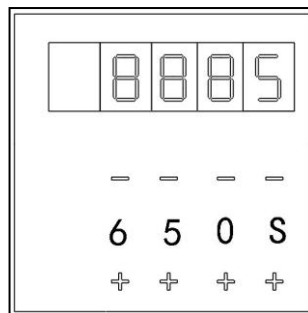

Diagram 4

>> Press Pressure Adjustment

- A. Turn the knob on the compress air filter regulator to adjust the press pressure
- B. By adjusting the four adjustment screws below the working table, the pressure of the press can also be changed, even under the same air pressure setting.

>> Operation Mode Selection

The machine has two operation modes:

- A. Manual Mode - Step on the left foot switch, the heating plate goes down. Once move away the foot, the heating plate goes up.
- B. Auto Mode - Step on the right foot switch, the heating plate goes down, after move away the foot, the timer starts to countdown. When the countdown is completed, the heating plate goes up.

> **Trouble Shooting**

Problem	Cause	solution
No power to individual parts	Fault with power cord or plug	Check the power connection
	Circuit breaker tripped	Reset the breaker and investigate the system
	Main power supply not switch on	Switch on the main power supply
	Bad contact	Check the circuit if there is any loosen part
	Transformer fault	Check the voltage of power supply
Temperature monitor unsteady	Thermocouple fault	Replace the temperature sensor
	Thermocouple connection is loosen	Check and tighten the connection
	Temperature controller malfunction	Replace the circuit board in the control box
	Thermocouple extension cable short circuit	Check the break point and repair
	Thermocouple installed in wrong position	Check the end point of the sensor and relocate the position of it
Temperature monitor showing the ambient temperature	Heater not started up	Press the heat button
	Air pressure too low	Check the air supply if any leakage point
	Thermocouple fault	Replace the thermocouple
	Power supply voltage unsteady	Install voltage stabilizer
Heater temperature cannot raises up	Solid state relay (SSR) malfunction	Replace the SSR
	Compressed air pressure too low and interlocked	Increase the compressed air pressure

Appendix A . Control Circuit Schematic Diagram

